



Using the MxC™200 Family In Transformerless Isolated Applications

By Jeff Sorensen, Application Engineer, [Helix Semiconductors](#)

Application Note 013

Introduction

The MxC200 family comprises five highly versatile products that can be used in a multitude of configurations. Their primary purpose is to convert DC input voltages to either a higher or lower DC voltage and in one case, also includes a H bridge push-pull driver stage. The other devices are used with the H bridge stage to implement different capacitively isolated configurations with a wide range of input and output voltages possible. This app note explains the differences between the products and shows three examples of isolated MxC200 family EVB boards that are currently available. Three different products are used in these TL (TransformerLess) Isolation EVBs. Please refer to the MxC™200 TL EVB Manual for detailed schematics and performance data.

- The 2I_048_010A is a 48 to 24V (nominally) DC divide by two charge pump followed by an H bridge driver. These outputs are intended to be used to drive a capacitively coupled isolation barrier. This is the key device needed in all the TL Isolation EVMs. The first HV charge pump stage can be powered by either its input or output pin. The input and output capacitor values depend on the particular application in which it is used. The “I” in the part number indicates it is an “interface” driver part, the middle number the nominal input voltage, and the last number the power.
- The 2D_024_010A accepts a 24V DC input and has two divide by 2 charge pump stages that can be used in series to get a divide by four or in parallel for higher efficiency as a divide by two. With 24V in this means the outputs can be either a 12V DC or 6V DC out, or both. By using the CFLY2BT output by itself, a negative output voltage can also be generated. Details on this configuration will be covered in a following section. The “D” in the part number indicates the voltage goes “Down” through the part.
- The 2U_012_010A is a 6V or 12V DC to 48V DC multiply by two or four charge pump stage. It can be used in conjunction with the 2I_048_010A to boost the input voltage for more efficient power transfer across a high voltage isolation barrier. The TL Isolation works most efficiently when the barrier uses 24Vpp signal levels. This product can be used to boost lower voltages to 24V to more efficiently transfer power. The “U” in the part number indicates the voltage goes “Up” through the part.

Isolated Operation

Figure 1 shows an example of a single cell for the charge pump and the push-pull driver. The main differences between the MxC200 family’s charge pump cells is the voltage rating of the cell and the phase relationship at their outputs. There is one high voltage stage (62V max) and two low voltage

stages (30V max) with a 180° phase relation to each other in the 2D_024_10A. The high voltage cell is only used to generate the gate drive voltages necessary to control the lower voltage switches.

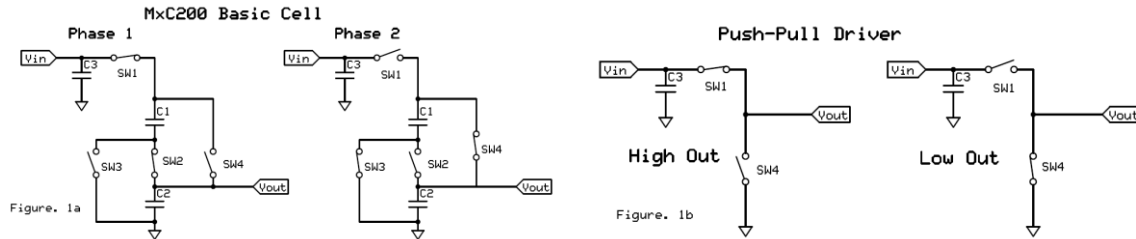

Figure 1 Figure 1a shows the basic charge pump cell in the MxC200 family, figure 1b shows the 2I_048_010A push-pull driver.

The push-pull driver in the 2I_048_010A shown in figure 1b is intended to be used with capacitive (Transformerless) isolation. The output of each H bridge driver is nominally 24V peak and 0V. The output of the driver goes through a capacitor and inductor to a full wave bridge rectifier and bulk capacitor; the rectified DC level of this driver stage is nominally 24V. This can then be used by other MxC200 family devices to generate other voltages

The capacitors used with the driver will determine the isolation level that can be achieved. For a design that meets UL certification levels, X1 or Y1 safety rated capacitors should be used. These are designed to fail in an open condition. If this level of isolation is not required by the application, other capacitors could be used, but many capacitors will fail in a shorted state if their voltage rating is exceeded. This may cause an unsafe condition, so if safety is the major concern, UL safety rated capacitors should always be used to prevent unsafe operation.

Although transformers are not used with this isolation method, there are inductors in the primary to secondary isolation networks. This improves the efficiency by canceling most of the impedance from the capacitors, as is the case in any L/C resonant circuit. The phase of the impedance of the inductor is opposite and cancels most the capacitive impedance when operated near resonance, so losses in the isolation barrier are minimized. Without these inductors, the efficiency would be seriously compromised.

Also, related to operating with components near their resonance, the clock for the 2I_048_010A bridge driver is usually operated at about 200kHz instead of the nominal 100kHz. This provides better efficiency with the recommended transformerless isolation network values. It is necessary to do some tuning based on the exact characteristics of the capacitors and inductors that are chosen. As long as the same values and manufactures are maintained, it is not necessary to “tune” each circuit. Precise tuning is not needed to get consistent performance. If vendors are changed, it may require adjusting the clock frequency and/or component values used. Efficiency is also helped by using the fewest number of stages in the power path. Each time a voltage is converted up or down, there will be some associated losses. By using fewer stages these losses can be minimized. Using stages in parallel helps efficiency, so in some cases the two lower voltage stages are used in parallel to improve efficiency. Since these are also 180° out of phase from each other, the output capacitance required can be lower for a given ripple voltage than when using a single stage.

Helix Semiconductor Evaluation Boards (EVBs)

Helix Semiconductor has three evaluation boards that demonstrate some of the ways the MxC200 family can be used in isolated applications. Input voltages from 6 to 48V can be used to deliver a number of different output voltages efficiently at a single or multiple output voltages. Helix Semiconductors (currently) has three isolated evaluation boards that show examples of single 6V and 12V output designs, as well as one with $\pm 12V$ and a regulated 5V output. There is also a 6V input to isolated 6V output evaluation board.

The input voltage does not need to be precise since the charge pump simply takes the input voltage and divides it (or multiplies it) by two, but generally speaking the higher the H bridge output voltage, without violating their maximum operating voltages, the more efficiently the power is transferred.

These designs all show superior efficiency and small size for their voltage and power levels. When a known load is being driven, the designs can be further optimized to get the smallest footprint and cost by the selection of capacitor values and package sizes that are used.

Converting 48V to an Isolated 12V: The MxC270 EVB

Figure 2 shows this concept as implemented in the MxC270 EVB. In this configuration the line-side 2I_048_010A uses the first high voltage stage to generate 24V DC to source the voltages for the two differential drivers. On the secondary side the rectified and filtered 24V is provided to the 2D_24_010A using a pair of divide by two charge pumps connected in parallel and operating with 180° phase relation to each other to generate 12V DC with greater efficiency. The capacitors for the high voltage stage charge pump are connected to Vout1, Vin1, and Cfly1 but are not in the power path. This charge pump stage is

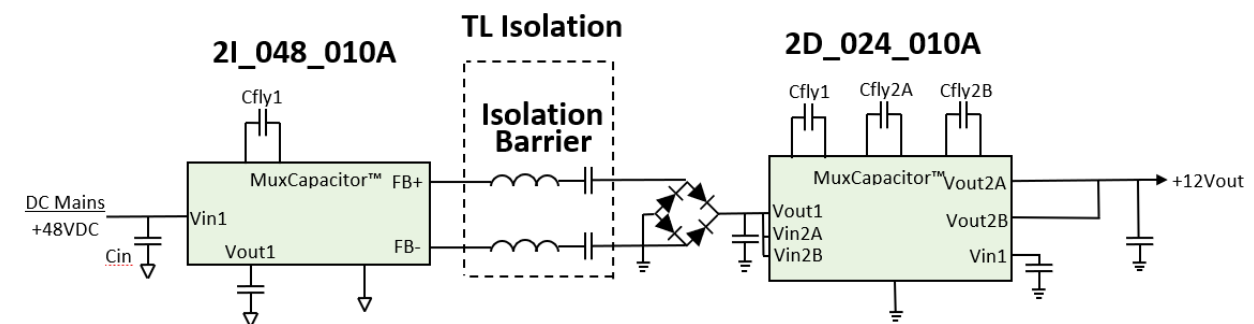

MxC 270 Evaluation Board

Figure 2 Block diagram of the MxC270 EVB showing voltage conversion and isolation from 48V to 12V DC

used to generate the gate driver voltage for the two low voltage divide by two charge pumps connected in parallel. This configuration is very efficient because there is a minimum number of voltage conversion stages in the power path. If only 24V was used for the input power, the first voltage reduction stage on the primary side could be bypassed like the secondary stage configuration by driving the Vout1 pin instead of the Vin1 pin.

Converting 6V to an Isolated 6V: The MxC271 EVB

It is always important that the voltage levels across the isolation barrier are as high as possible to get the best efficiency. The isolation barrier should therefore be operated as near the maximum input voltage as possible. In a case where the input voltage is relatively low, e.g., near 6V, the 2U_012_03A can be operated in boost mode by using the two lower voltage charge pumps in series to multiply the voltage by four to get 24V on the primary side, then use this to source the 2I_048_010A used as a differential driver, as shown in figure 3. This is the configuration used in the MxC271 6V input to 6V output, transformerless isolation evaluation board (EVB). The frequency for the 2U_012_03A is also increased to improve the efficiency of the boost stage. Because there are more voltage conversion stages to up-convert and then down-convert the voltage levels, this is less efficient than the other EVBs for the MxC 200 family. But this is still more efficient than would be the case if the added stages were not used to increase the voltage levels across the isolation barrier.

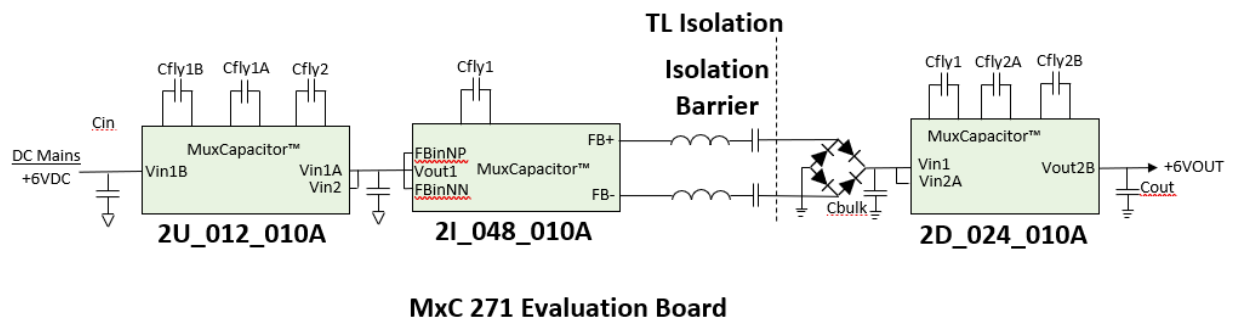

Figure 3 Circuit block Diagram of the 6V to Isolated 6V Operation of the MxC271 EVB

The two lower voltage stages of the 2U_012_010A are connected in series to generate 24V. This is then connected to its high voltage stage through its Vin2 pin for the gate drivers as well as source the power to 2I_048_010A's high-side bridge switches. On the secondary side the rectified and filtered 24V is fed to the input of the first low voltage stage in series with the second low voltage stage, each operated in the divide by 2 mode, to get 6V DC. 12V and 24V DC are also available on the secondary side as well, and could also be used, but keep in mind the total combined power available to all the stages is always the same. Even the first high voltage stage of the 2D_024_010A could be used to provide 48V if appropriate capacitors are used for its flying capacitor and Vin1 pin. As the voltage is increased through the stages the available current is decreased.

When the 2U_012_010A is being used, it is necessary to assure the maximum voltage ratings of the stages will not be exceeded by using an input voltage that will result in output voltages being above their operating limit. When the stages are all used in series to get a boost in voltage, the first stage should not exceed about 7V. If only one low voltage stage is used or two are used in parallel to boost the voltage, the low voltage stage should be sourced from no more than 14V, so its output does not exceed 28V Vmax on its output. The high voltage stage must also be powered, so it cannot see more than 28V at its Vin2 input to stay below its operating voltage limit of 57V at Vout2.

Converting from 48V to +/-12V, Plus a Regulated 5V DC: The MxC273 EVB

Figure 4 shows a block diagram of the MxC273 EVB. This is similar to the MxC270, but on the secondary side, instead of a single 12V output, a split $\pm 12V$ supply is implemented, along with a +5V regulator connected to the +12V output. The primary side is identical to the MxC270. In this design, the secondary uses the two lower voltage charge pumps independently instead of in parallel. One is used to generate the +12V voltage and this is also the supply sourcing the +5V regulator. The other low voltage charge pump is used to generate the negative 12V supply through a discrete diode/capacitor charge

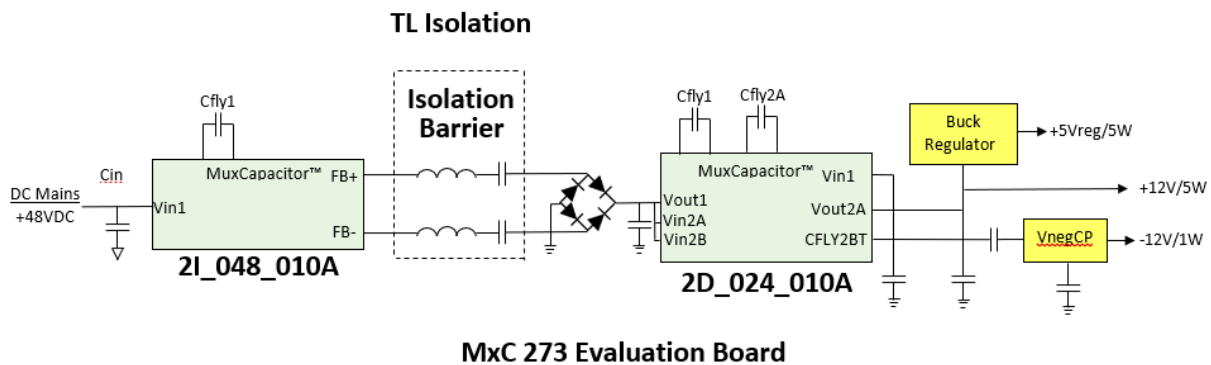

Figure 4 Block diagram for the MxC273 48V to +/-12V and Regulated +5V EVB

pump driven from the CFLY2BT driver used as a single 24V square wave source with the VOUT2B connected to ground. This is then AC coupled into an external diode/capacitor discrete charge pump to generate the negative 12V power.

The positive 12V output is also used for the voltage source for a 5V buck regulator. This regulator could provide any of a number of different positive output voltages, depending on the feedback resistor that is used.

The total power available is again limited by the total power of all the loads connected to the secondary outputs. Some care should be taken to assure that using multiple loads does not adversely affect operation on each output. Often some additional capacitance in the charge pump circuits will improve the performance if more current is required. Both the output and flying capacitor can benefit from more capacitance in many cases where a large load is being driven. Each charge pump stage in the voltage reduction mode has over current protection, which looks at the slope of the flying capacitor voltage to determine whether its maximum load is being exceeded. Additional capacitance will often help preventing premature over-current detection by reducing the peak to peak levels to the detector. When used in the voltage boost mode, the current limit is disabled, so some care is needed to not



exceed the power limits when using boost mode. If the loading on the outputs becomes excessive and the devices get too hot, the thermal shutdown is still there to prevent damage.

Parallel Operation

Another interesting feature of the MxC200 family is that they can also be connected in parallel. If more power is needed than can be supplied by a single device, they can easily be connected in parallel. Each device self regulates such that they will share the loads equally. Special circuitry is not required to do this. The inputs and outputs of each section can be connected to the like signal on another device to increase the power that can be supplied. This means the DC Vin and Vout of each device can be connected to the like pin(s) on another device. Otherwise the other pins, such as the Cflys and other dynamic or internal pins, should be not be connected together. In an isolated design this means that the bridge drivers would need to also be connected to their separate coupling networks to work correctly since these are not DC. The reason these pins cannot be connected is that the clocking for the flying capacitors and bridge drivers are not coming from a common timing source and would interfere with each other if those signals were connected from different devices. Multiple MxC200 devices have been connected in this way to generate up to a kilowatt of power.